



www.offmax.com.hk

offmax

Offmax Limited 奧美斯傢具有限公司
Offmax Supplies Co., Ltd 奧美斯洋行

Hong Kong Head Office / Showroom* 香港總辦事處 / 展廳
10/F, North Point Industrial Building, 499 King's Road, North Point, Hong Kong
香港北角英皇道499號北角工業大廈10樓
Tel 電話: (852) 2838 3830 Fax 傳真: (852) 2553 0088
Email 電郵: enquiry@offmax.com.hk

*Please make appointment before visiting our showroom
*如欲參觀，敬希預約

Shanghai Sales Office 上海辦公室
Tel 電話: (86) 021-6167 3668

All rights reserved. Any reproduction or modification in any form or by any means without prior written permission is illegal and strictly prohibited.
本冊版權為奧美斯所有，未經書面同意，任何單位或個人不得以任何方式或理由使用、複製、修改、抄錄或傳播圖冊內述的任何部分。

With continuous product development, design and specification are subjected to possible modification without prior notice.
為不斷改良產品質量，設計及規格日後若有更改，恕不另外通知。

Compactus



Manual Type Mobile Filing Cabinet (One & Two Bay)



Handle
手殼式把手



Handle
拉手



Wheel Handle
轉盤



Aisle Safety Lock
通道安全鎖



Index Holder
目錄座



Aisle Safety Lock
通道安全鎖



Anchor Shaped
Handle Lock
錨型手把鎖



Bumper
防撞膠墊

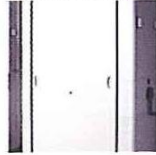

Sliding Door with
Lock
橫移門連鎖



Platform
平臺



Two Bay Mobile Filing Cabinet (Manual Type) 二連手動式直推櫃

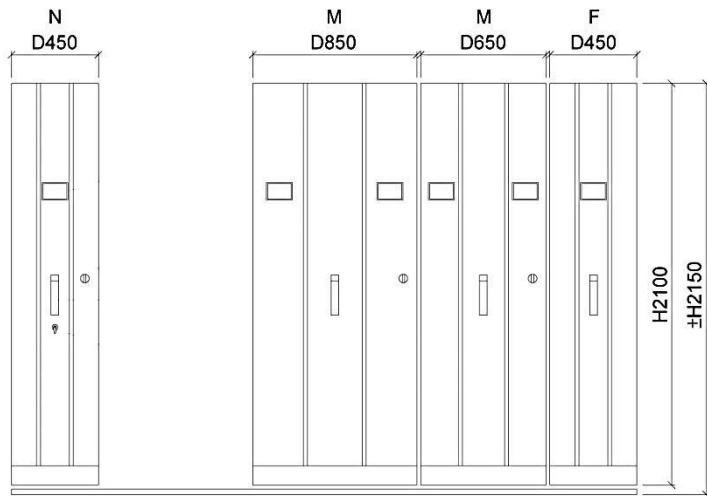

側視圖

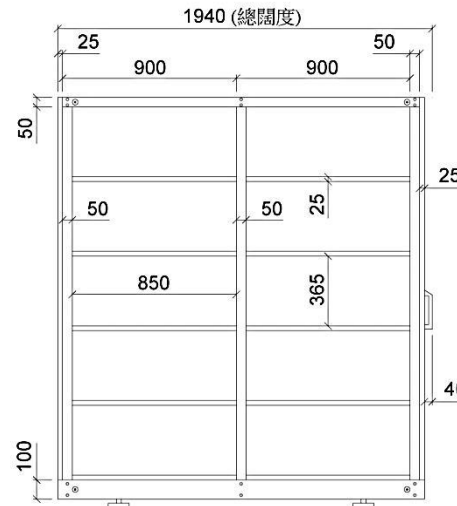

正視圖

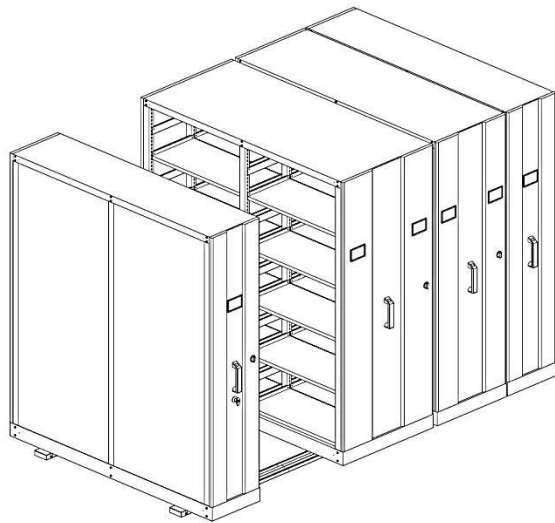

- 拉手物料: ABS 塑膠 (只有深灰色)
- 連數: 1-2

- Handle Material : ABS Plastic (Charcoal Only)
- Bay Qty. : 1-2

備註:

- F - 單面固定櫃 (D450)
- N - 單面活動櫃 (D450)
- M - 雙面活動櫃 (D650 / 850)

Remark :

- F-Single Face Fixed Unit (D450)
- N-Single Face Movable Unit (D450)
- M-Double Face Movable Unit (D650 / 850)

總闊度公式:

900 * 連數 + 140mm
(例如: 總闊度1940 = 900 * 2連 + 140mm)

Total Width Formula : 900* Qty. of Bay +140mm
(e.g Total Width 1940 = 900* 2Bay + 140mm)

Mechanical Wheel Type Mobile Filing Cabinet

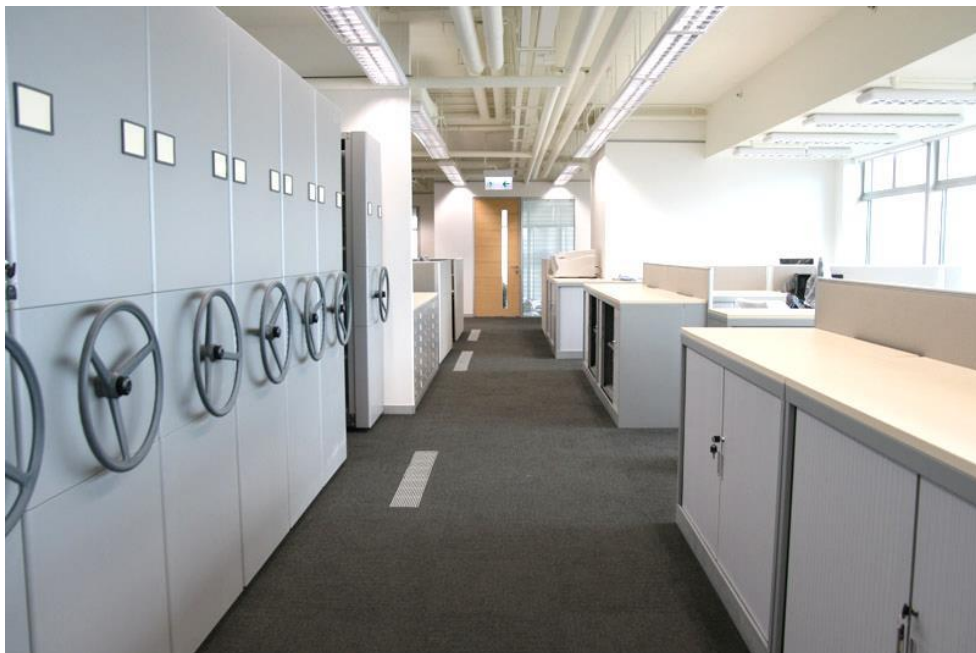

Handle
手殼式把手



Handle
拉手



Wheel Handle
轉盤



Aisle Safety Lock
通道安全鎖



Index Holder
目錄座



Aisle Safety Lock
通道安全鎖



Anchor Shaped
Handle Lock
錨型手把鎖



Bumper
防撞膠墊

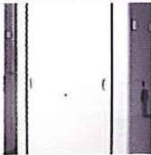

Sliding Door with
Lock
橫移門連鎖



Platform
平臺

Two Bay Mobile Filing Cabinet (Mechanical Type) 二連機械式直推櫃 (轉盤款)

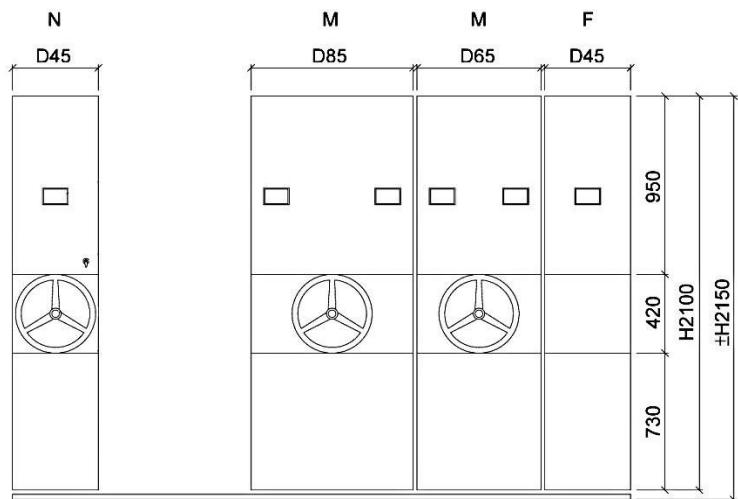

側視圖

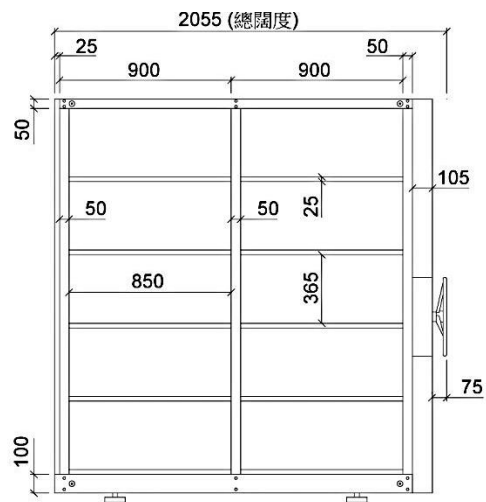

正視圖

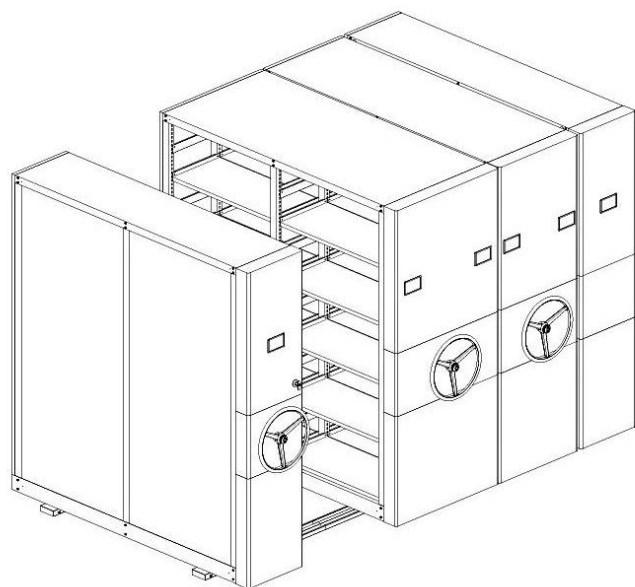

- 曲柄物料: ABS 塑膠 (只有深灰色)
- 連數: 1-8

備註:

F - 單面固定櫃 (D450)

N - 單面活動櫃 (D450)

M - 雙面活動櫃 (D650 / 850)

總闊度公式:

$900 * \text{連數} + 270\text{mm}$

(例如: 總闊度2070 = $900 * 2\text{連} + 270\text{mm}$)

- Handle Material : ABS Plastic (Charcoal Only)
- Bay Qty. : 1-8

Remark :

F-Single Face Fixed Unit (D450)

N-Single Face Movable Unit (D450)

M-Double Face Movable Unit (D650 / 850)

Total Width Formula : $900 * \text{Qty. of Bay} + 270\text{mm}$
(e.g Total Width 2070 = $900 * 2\text{Bay} + 270\text{mm}$)

Mechanical Handle Type Mobile Filing Cabinet



Two Bay Mobile Filing Cabinet (Handle Type) 二連機械式直推櫃 (手搖款)

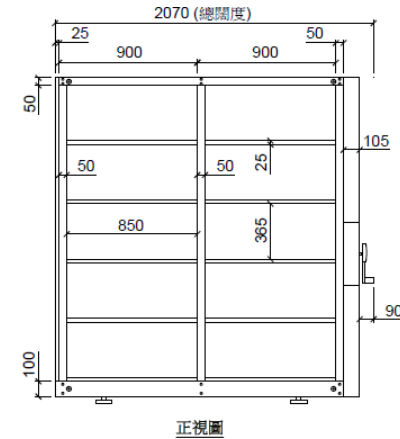
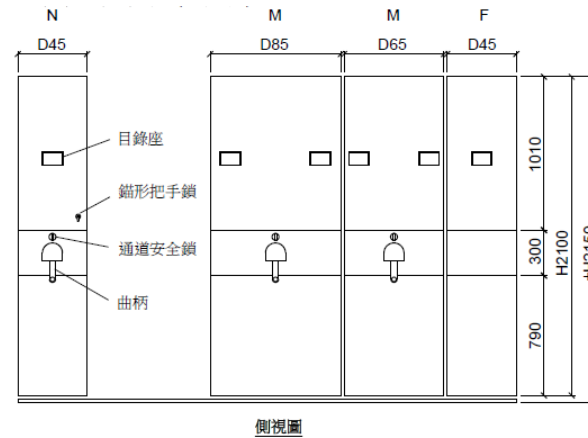

- 曲柄物料: ABS 塑膠 (只有深灰色)
- 連數: 1-8

備註:

- F - 單面固定櫃 (D450)
- N - 單面活動櫃 (D450)
- M - 雙面活動櫃 (D650 / 850)

總闊度公式:

900 * 連數 + 270mm
(例如: 總闊度2070 = 900 * 2連 + 270mm)

- Handle Material : ABS Plastic (Charcoal Only)
- Bay Qty. : 1-8

Remark :

- F-Single Face Fixed Unit (D450)
- N-Single Face Movable Unit (D450)
- M-Double Face Movable Unit (D650 / 850)

Total Width Formula : 900* Qty. of Bay +270mm
(e.g Total Width 2070 = 900* 2Bay + 270mm)

Compactus Series ~ Accessories 活動直推櫃配件

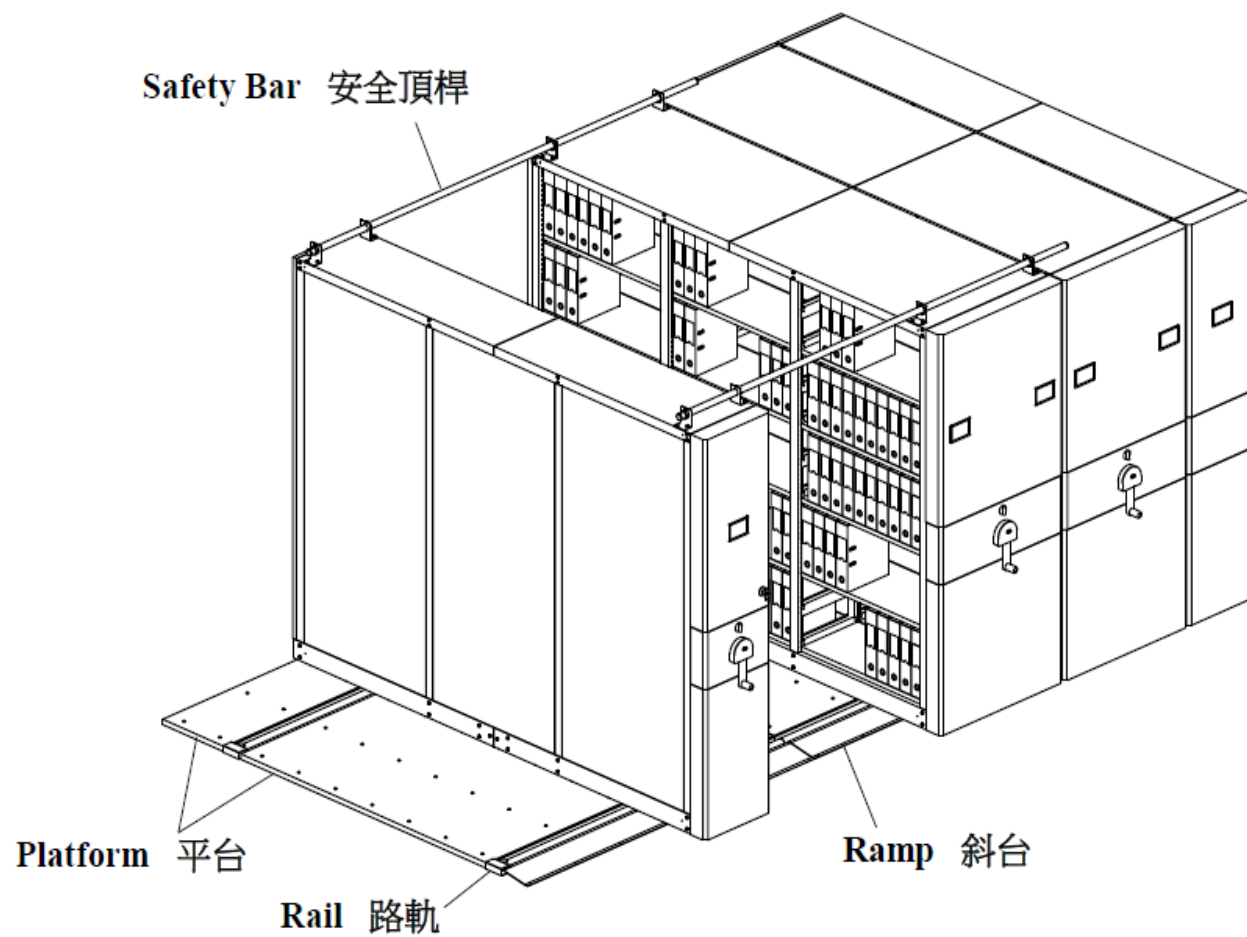

Platform











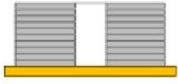

Ramp



Rail







Specification

Dimension of pull out filing w/o hanger swinging doors.

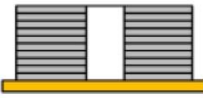
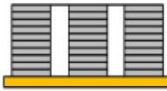
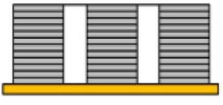
Size	W845 x D294	W845 x D410	W1245 x D294	W1245 x D410
A4 横掛				
F4 横掛				
F4 直掛				

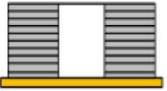

Dimension of pull out filing w/o hanger swinging doors.

Size	W845 x D380	W845 x D410	W1245 x D380	W1245 x D410
A4 横掛				
F4 横掛				
F4 直掛				



Accessories



SW-01RS-□□
Reinforced Shelf (for 650)
加強活動層板 (650用)
W845 x D295 x H25mm



SW-05PF-□□
Pull-Out Frame
活動文件架



SW-10CB-□□
Central Bar (for 650/850)



SW-01HR-□□
Hanging Rod (for 450/850)
雙掛通 (450/850用)



SW-08PD-□□
Pull-Out Drawer
分格櫃
W823 x D414 x H115mm



SW-02RS-□□
Reinforced Shelf (for 450/850)
加強活動層板 (450/850用)
W845 x D295 x H25mm

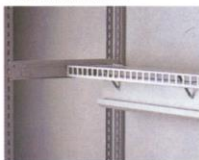

SW-06MH-□□
Magnetic-Tape hanger
電腦帶掛架



SW-11CP-□□
Full Length Central Panel



SW-04PT-□□
Pull-Out Desk Top
活動移門連頭
W818 x D397 x H20mm

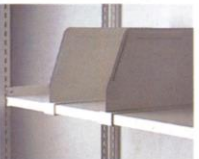

SW-09DV-□□
Divider
分格櫃
H200mm



SW-02MS-□□
Multi-Purpose Shelf (for 450/850)
多用活動層板 (450/850用)
W845 x D395 x H25mm

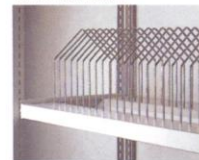

SW-07MR-□□
Magnetic Tape Rack
電腦帶座架



SW-12PH-□□
Pigeon Hole Cabinet
文件格
W840 x D390 x H300mm



SW-13SD-□□
Sliding Door with Lock
活動移門連鎖
W848 x D57 x H1948mm



SW-14DD-□□
Double Swing Door with Lock
雙掩門連鎖
W848 x D50 x H1948mm

Specifications of Mobile Filing Cabinet 活動組合文件直推櫃規格

Types: 類別:	Manual 手動式	Mechanical Wheel 機械轉盤式	Mechanical Handle 機械手殼式	
Material 材料:	Japanese Electrolytic Galvanized Steel 日本電解鐵片			
Finish 表面塗層:	Epoxy Powder Coating 靜電噴塗塗層			
Dimension: Width 闊度:	900n + 140mm	900n + 255mm	900n + 270mm	
Size: 尺寸:	Height 高度:	2150mm		
	Depth 深度:	Fixed Unit 固定櫃: 450mm; Movable Unit 活動櫃: 450 / 650 / 850mm		
Shelf Size 層板尺寸:	W845 x D395 x H25mm (for 450 / 850); W845 x D295 x H25mm (for 650)			
No. of Shelf 層板數量:	Single Fixed 單面固定/ Single Movable 單面活動 = 4n; Double Movable 雙面活動 = 8n			
Loading per Shelf: 層板承重量:	Reinforced Shelf 加強活動層板: D295mm/85kg; D395mm/100kg Multi-purpose Shelf 多用活動層板: D395mm/70kg			
Net Weight: 淨重:	Single Fixed: 單面固定:	51(n-1)+90kg	51(n-1)+90kg	51(n-1)+88kg
	Single Movable: 單面活動:	61(n-1)+108kg	60(n-1)+118kg	60(n-1)+116kg
	Double Movable (650): 雙面活動 (650):	94(n-1)+121kg	71(n-1)+137kg	71(n-1)+135kg
	Double Movable (850): 雙面活動 (850):	108(n-1)+134kg	85(n-1)+164kg	85(n-1)+162kg
No. of Rails 路軌數量:	1-3 Bays 連: 2pcs條	4-5 Bays 連: 3pcs條	6-7 Bays 連: 4pcs條	8 Bays 連: 5pcs條
Aisle Size 通道尺寸:	600-900mm			
Material Thickness: 材料厚度:	Base 底架: 2mm Top Panel 頂板: 1mm Side Panel 側板: 1mm	Back Panel 背板: 1mm Shelf 層板: 1mm	Rail 路軌: 2mm Post 支柱: 1.6mm	
Lock: 鎖:	Zinc alloy die casting (ZDC) handle with Nickel-chromium (ZCr) plating finish 鋅合金鑄造拉手, 表面鍍上鎳鉻層			
Post: 支柱:	U-shaped post of double plate with slots in 26mm increment "U"形支柱兩旁連26mm連排孔			
Bumper 防撞膠墊:	Natural rubber of Ø 30 x 16mm 直徑 30 x 16mm 天然橡膠			
Rail: 路軌:	Made of 25mm concrete steel with 0.8mm stainless steel sheet coating 採用25mm實心鋼鐵材料, 鋼鐵外層包0.8mm不銹鋼片			
Wheel: 滑輪:	Iron die casting with anti-rust zinc coating 生鐵鑄造, 表面鍍防銹鋅層 Loading 荷重: 1000kg/wheel 滑輪			

Remarks: n=Number of bay
備註: n=連數

